

**ATTENTION:
BASIC MODEL**

FRAME LEVELS

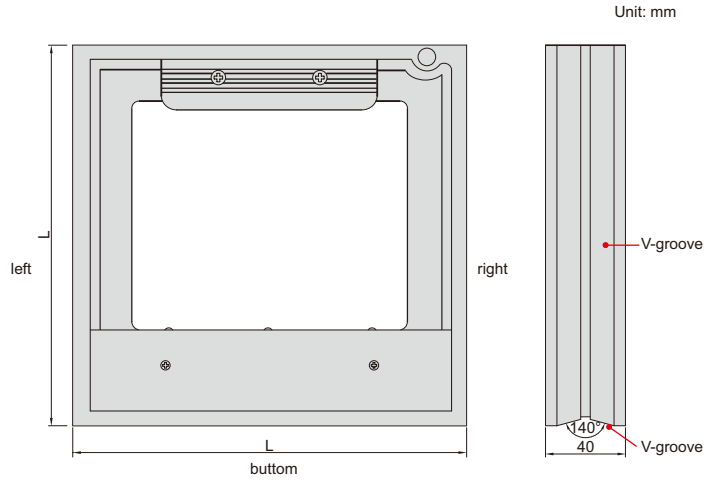

4902-200



Code		Size(LxL)
Sensitivity 0.02mm/m(=0.001°)	Sensitivity 0.05mm/m(=0.0029°)	
4902-150	4902-C150	150x150mm
4902-200	4902-C200	200x200mm
4902-300	4902-C300	300x300mm

- V-groove on bottom and left for shafts (shafts dia. 15~70mm)
- With transverse vial
- Supplied with adjusting wrench