

THREAD HEIGHT MEASURING INSTRUMENTS

MEET INTERNATIONAL
STANDARD API5B

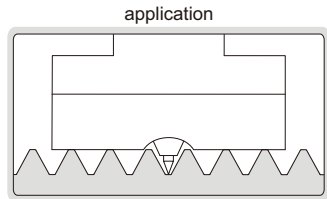

- Measure the height of external thread and internal thread with nominal diameter larger than 5 1/2" (139.7mm)
- Optional accessory: thread height standard blocks (code **6250**)



2232-35

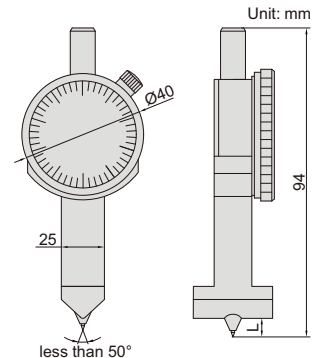

| Code | Range (L) | Dial indicator graduation | Accuracy |
|-----------------|-----------|---------------------------|----------|
| 2232-35 | 0-3.5mm | 0.01mm | 0.02mm |
| 2232-35E | 0-1/4" | 0.0005" | 0.0008" |