

INSIDE GROOVE CALIPERS

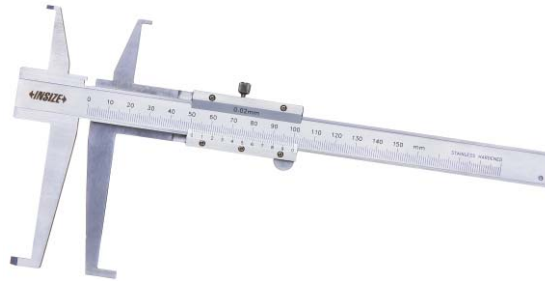

1199-150

depth stop **6143**
(optional)



- Measure diameter of grooves inside bores
- Graduation: 0.02mm
- Made of stainless steel
- Optional accessory: depth stop (code **6143**)

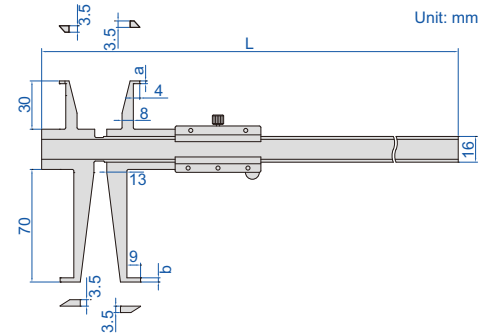

sizes to be measured
(use upper jaws)

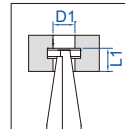

D1		L1	
Ø9	<8		
Ø10	<12		
Ø11	<15		
Ø12	<20		
Ø13-300	<30		

sizes to be measured
(use lower jaws)

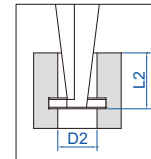

D2		L2	
Ø18	<30		
Ø19	<40		
Ø20	<45		
Ø21	<55		
Ø22	<60		
Ø23-300	<70		

Code	Range of upper jaw	Range of lower jaw	Accuracy	L	a	b
1199-150	9-150mm	18-150mm	±0.04mm	248mm	1.6mm	2.5mm
1199-200	9-200mm	18-200mm	±0.05mm	298mm	1.8mm	2.8mm
1199-300	9-300mm	18-300mm	±0.06mm	398mm	2.0mm	3.0mm